

# Dimensions (1-stage, Ratio i=3~10)

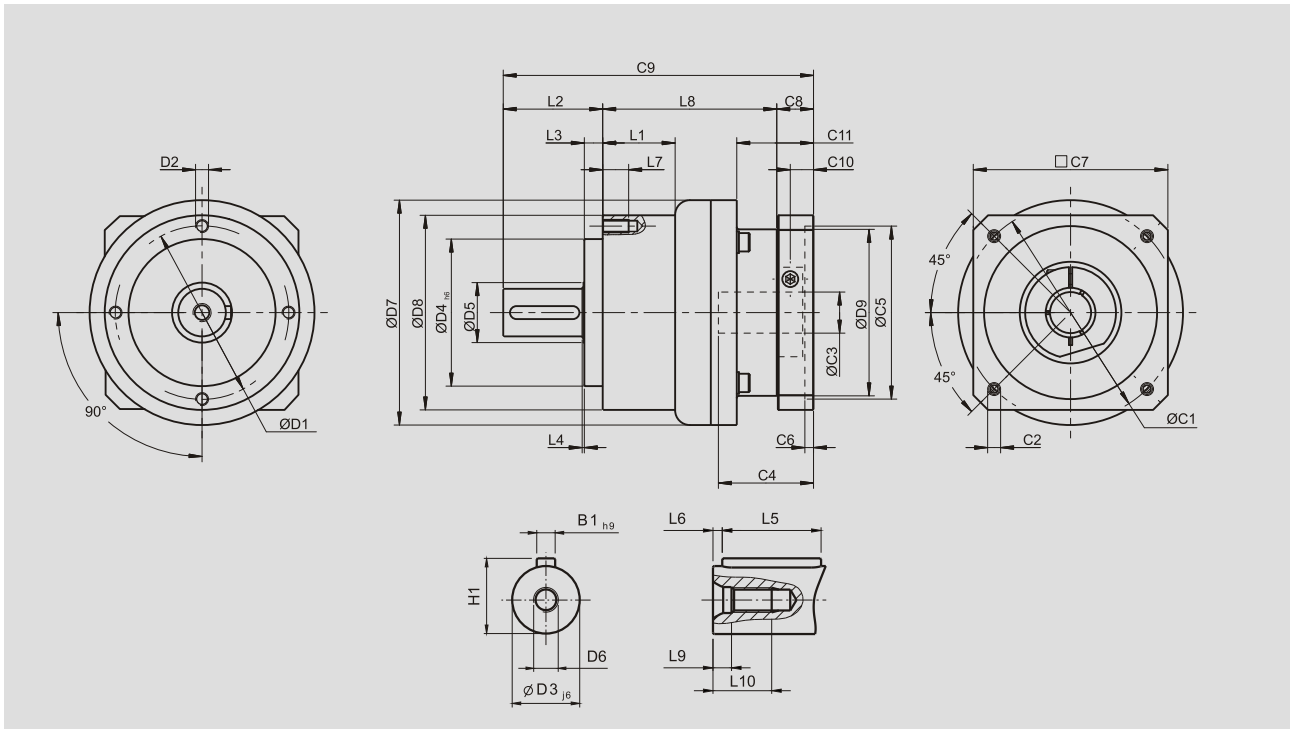

[unit: mm]

Dimension	AE050	AE070	AE090	AE120	AE155	AE205	AE235
D1	44	62	80	108	140	184	210
D2	M4 x 0.7P	M5 x 0.8P	M6 x 1P	M8 x 1.25P	M10 x 1.5P	M12 x 1.75P	M16 x 2P
D3 <sub>j6</sub>	12	16	22	32	40	55	75
D4 <sub>h6</sub>	35	52	68	90	120	160	180
D5	22	22	30	40	75	95	115
D6	M4 x 0.7P	M5 x 0.8P	M8 x 1.25P	M12 x 1.75P	M16 x 2P	M20 x 2.5P	M20 x 2.5P
D7	53	70	104	130	162	205	260
D8	50	70	90	120	155	205	235
D9	45.5	53.4	77	102	125	160	205
L1	--	--	33.5	38	50	--	70
L2	24.5	36	46	70	97	100	126
L3	4	6.5	8.5	17.5	15	15	18
L4	1	1	1	1.5	3	3	3
L5	14	25	32	40	63	70	90
L6	2	2	3	5	5	6	7
L7	8	10	12	16	20	22	28
L8	47	62	80.5	97	119.5	159	175.5
L9	4.5	4.8	7.2	10	12	15	15
L10	10	12.5	19	28	36	42	42
C1 <sup>4</sup>	46	70	100	130	165	215	235
C2 <sup>4</sup>	M4 x 0.7P	M5 x 0.8P	M6 x 1P	M8 x 1.25P	M10 x 1.5P	M12 x 1.75P	M12 x 1.75P
C3 <sup>4</sup>	★ ≤11 / ≤12	★ ≤14 / ≤16	≤19 / ≤24	≤32	≤38	≤48	≤55
C4 <sup>4</sup>	30	34	40	50	60	85	116
C5 <sup>4</sup>	30	50	80	110	130	180	200
C6 <sup>4</sup>	3.5	8	4	5	6	6	6
C7 <sup>4</sup>	48	60	90	115	142	190	220
C8 <sup>4</sup>	19.5	19	17	19.5	22.5	29	63
C9 <sup>4</sup>	91	117	143.5	186.5	239	288	364.5
C10 <sup>4</sup>	13.25	13.5	10.75	13	15	20.75	53.5
C11 <sup>4</sup>	19.5	37	35.5	46	53.5	79.5	106.5
B1 <sub>h9</sub>	4	5	6	10	12	16	20
H1	14	18	24.5	35	43	59	79.5

4. C1~C11 are motor specific dimensions (metric std shown). Refer to Apexdyna.com and Design Tool to view your specific motor mounting system.

★ AE050 ratio 5, 10 offers C3 ≤ 12 option. ★ AE070 ratio 5, 10 offers C3 ≤ 16 option.

# AE Series

## Dimensions (2-stage, Ratio $i=15\sim 100$ )

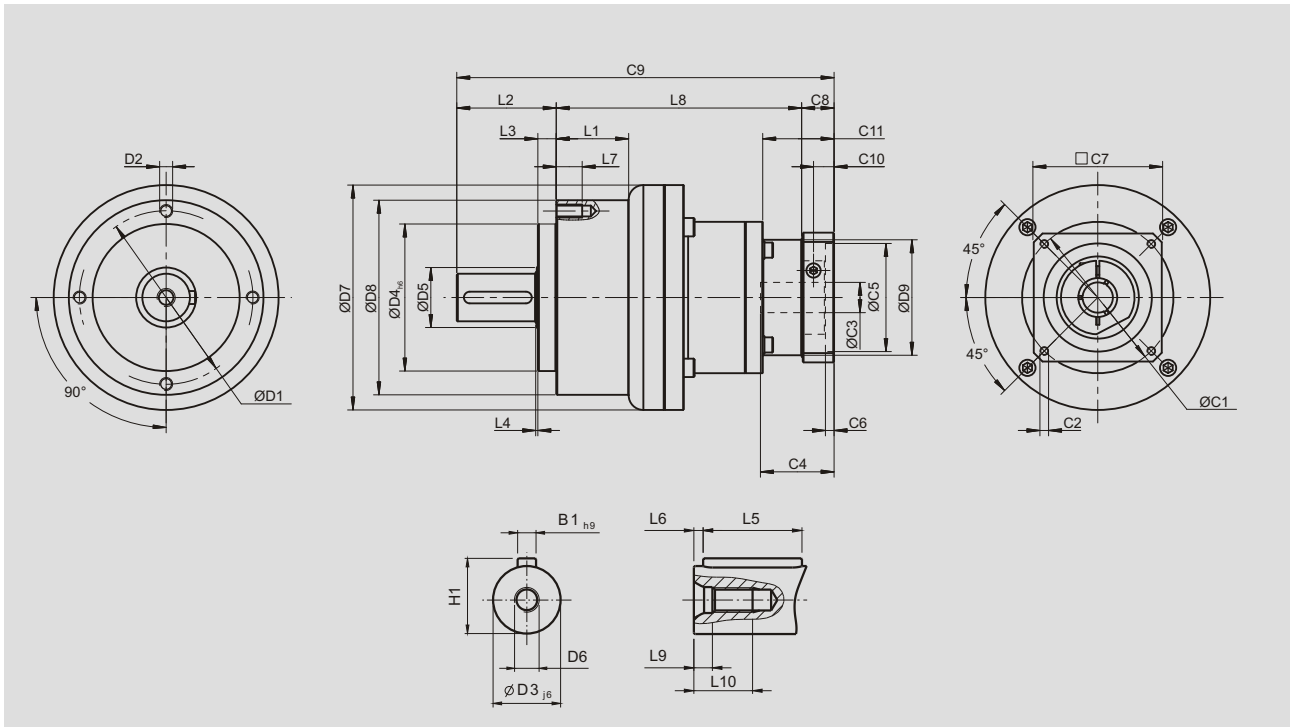

[unit: mm]

Dimension	AE050	AE070	AE090	AE120	AE155	AE205	AE235
D1	44	62	80	108	140	184	210
D2	M4 x 0.7P	M5 x 0.8P	M6 x 1P	M8 x 1.25P	M10 x 1.5P	M12 x 1.75P	M16 x 2P
D3 <sub>j6</sub>	12	16	22	32	40	55	75
D4 <sub>h6</sub>	35	52	68	90	120	160	180
D5	22	22	30	40	75	95	115
D6	M4 x 0.7P	M5 x 0.8P	M8 x 1.25P	M12 x 1.75P	M16 x 2P	M20 x 2.5P	M20 x 2.5P
D7	53	70	104	130	162	205	260
D8	50	70	90	120	155	205	235
D9	45.5	45.5	53.4	77	102	125	160
L1	--	--	33.5	38	50	--	70
L2	24.5	36	46	70	97	100	126
L3	4	6.5	8.5	17.5	15	15	18
L4	1	1	1	1.5	3	3	3
L5	14	25	32	40	63	70	90
L6	2	2	3	5	5	6	7
L7	8	10	12	16	20	22	28
L8	74	87.5	113.5	138.5	176	214.5	260
L9	4.5	4.8	7.2	10	12	15	15
L10	10	12.5	19	28	36	42	42
C1 <sup>5</sup>	46	46	70	100	130	165	215
C2 <sup>5</sup>	M4 x 0.7P	M4 x 0.7P	M5 x 0.8P	M6 x 1P	M8 x 1.25P	M10 x 1.5P	M12 x 1.75P
C3 <sup>5</sup>	≤11 / ≤12	≤11 / ≤12	≤14 / ≤15.875 / ≤16	≤19 / ≤24	≤32	≤38	≤48
C4 <sup>5</sup>	30	30	34	40	50	60	85
C5 <sup>5</sup>	30	30	50	80	110	130	180
C6 <sup>5</sup>	3.5	3.5	8	4	5	6	6
C7 <sup>5</sup>	48	48	60	90	115	142	190
C8 <sup>5</sup>	19.5	19.5	19	17	19.5	22.5	29
C9 <sup>5</sup>	118	143	178.5	225.5	292.5	337	415
C10 <sup>5</sup>	13.25	13.25	13.5	10.75	13	15	20.75
C11 <sup>5</sup>	19.5	19.5	37	35.5	46	53.5	79.5
B1 <sub>h9</sub>	4	5	6	10	12	16	20
H1	14	18	24.5	35	43	59	79.5

5. C1~C11 are motor specific dimensions (metric std shown). Refer to Apexdyna.com and Design Tool to view your specific motor mounting system.

# Output Dimensions

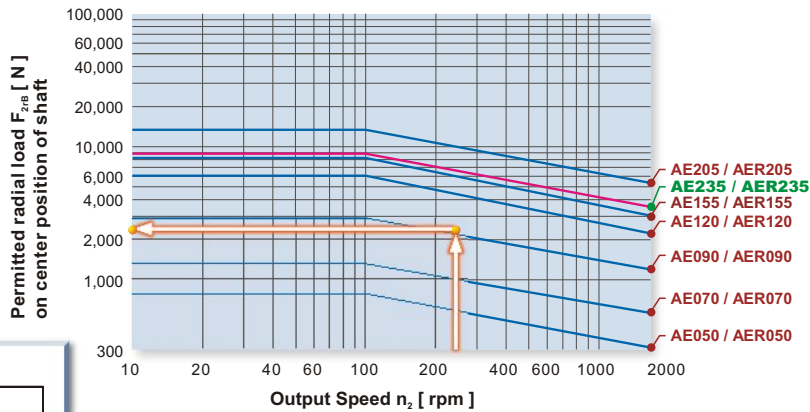

If radial force  $F_{2r}$  exert on the center of the output shaft  $X=1/2 \times L$ . Under various operating condition the lifetime is over 20,000\* hours. The permitted radial load is given on left diagram.

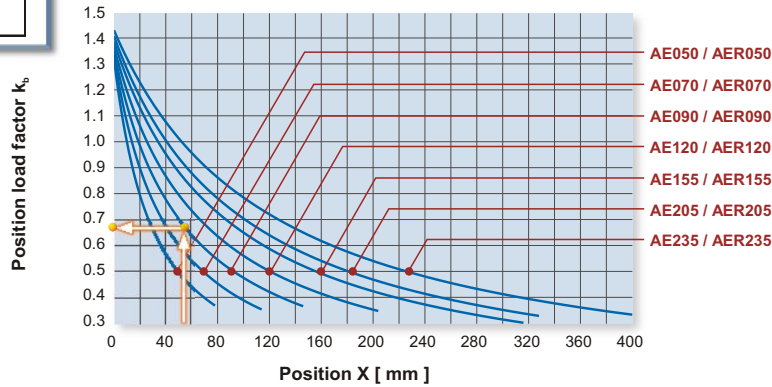
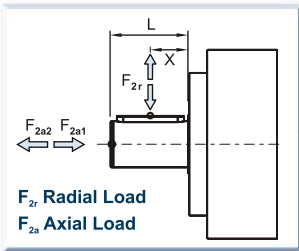

If radial force  $F_{2r}$  not exert on the center of the output shaft  $X < 1/2 \times L$  or  $X > 1/2 \times L$ . The permitted radial and axial load can be calculated by the position load factor  $k_b$  on the left diagram.

\* Continuous running reduces service life by 50%

## Front plate option

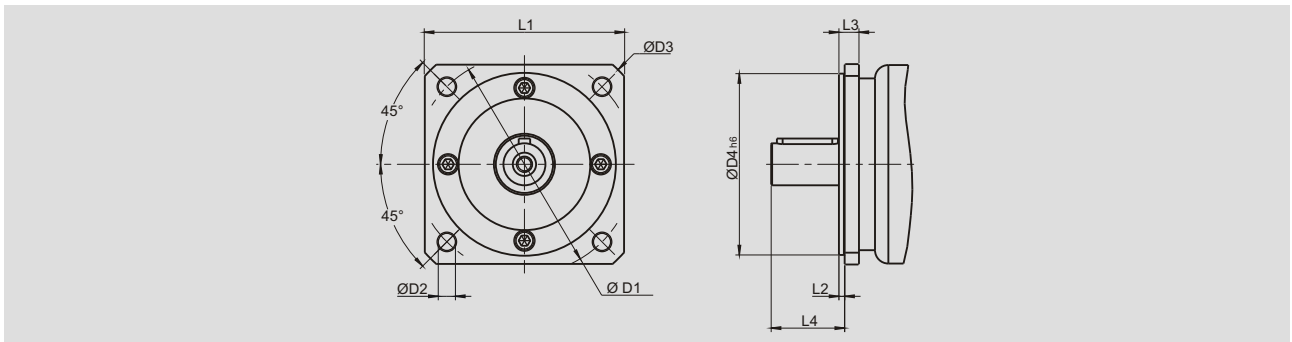

[unit: mm]

Dimension	D1	D2	D3	D4 <sup>h6</sup>	L1	L2	L3	L4
AE050(AER050)-NEMA 23	66.675	6	77	38.1	57.2	2	8	18.5
AE050(AER050)-PX60	70	5.6	80.5	50	60	2.5	8.5	18.5
AE070(AER070)-Metric	90	6.6	106	50	80	3	11	28
AE070(AER070)-NEMA 34	98.425	5.6	115	73.08	86	2.5	8	30.5
AE070(AER070)-DT90 / PX90	100	6.6	120	80	90	3	8	31
AE090(AER090)-IEC 63D5 B5	115	9	140	95	105	3	10.5	38.5
AE090(AER090)-NEMA 34	98.425	5.5	122	73.025	92	2.5	12.5	36
AE090(AER090)-DT90 / PX90	100	6.5	122	80	92	2.5	12.5	36
AE090(AER090)-NEMA 42	125.73	7	144	55.58	107	4	14.5	35.5
AE120(AER120)-NEMA 42	125.73	7.1	170	55.499	127	1.5	21.5	50
AE120(AER120)-NEMA 56	149.225	6.6	170	114.3	127	3	17.5	55.5
AE155(AER155)-B5	175	11	196	130	160	5	20	82
AE205(AER205)-B5	230	13	277	180	210	5	23	82
AE235(AER235)-B5	275	17	317	235	240	5	23	108